

Epcon G5^{pro}

High - Strength Epoxy Adhesive



RamsetTM



C orporate Profile	03
O n-Site Tensile Pull-out Test Procedure	05
D esign Guide	06
R ebar	06
A nchor Stud	14
T est Reports & Approvals	19



Corporate Profile

About ITW

Founded in 1912, Illinois Tool Works or ITW (NYSE: ITW) is a Fortune 200 company that produces engineered fasteners and components, equipment and consumable systems, and specialty products. It is based in Glenview, Illinois, with operations in 57 countries that employ approximately 49,000 women and men who adhere to the highest ethical standards. These talented individuals, many of whom have specialized engineering or scientific expertise, contribute to our global leadership in innovation. We are proud of our broad portfolio of approximately 16,000 active and pending patents.

ITW's recipe for success has been consistent: value added products and outstanding service win the day with customers. We place a high premium on the development of highly engineered products and systems—most of which are developed in tandem with our customers. And we continue to ensure that our customers receive timely, cost-effective service for the innovative products we provide.

We're Everywhere

ITW's products and solutions are at work all over the world, in deep-sea oil rigs, aerospace technology, bridges and wind turbines, healthcare, the spaces in which we live and work, the cars we drive, and the mobile devices we rely on. We are never, whether we know it or not, more than a few steps from an innovative ITW solution.

ITW Business Segments

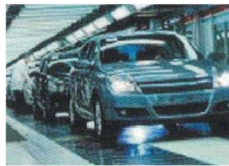

Automotive OEM. ITW Global Automotive specializes in the design and manufacture of metal, plastic, cold-formed and other related fasteners and products for automobiles and trucks.



Polymers & Fluids. Adhesives, sealants, lubrication and cutting fluids, janitorial and hygiene products, and fluids and polymers for auto aftermarket maintenance and appearance.



Test & Measurement and Electronics. Equipment, consumables and related software for testing and measuring of materials and structures, and equipment and consumables used in the production of electronic subassemblies and microelectronics.



Welding. Arc welding equipment, consumables and accessories for a wide array of industrial and commercial applications.



Food Equipment. Commercial food equipment and related service.



Specialty Products. Diversified segment includes beverage packaging equipment and consumables, product coding and marking equipment and consumables, and appliance components and fasteners.



Construction Products. Construction fastening systems and truss products for the commercial, residential and remodeling/ renovation sectors

The **Construction Products** segment established its base in Asia in 1973 by opening, in Singapore, a wholly owned subsidiary of ITW known today as ITW Construction Products (Singapore).

With the objective of providing customers' satisfaction, ITW expanded its presence in Asia by opening local entities in various markets such as Hong Kong (1974), Mainland China (1998), Thailand (2008), Indonesia (2011), Vietnam 2012. Today, ITW Construction Products (Singapore) also sells through selected distributors in Malaysia, Philippine and Korea.

Trusted Construction Brands Owned by ITW



ITW-Owned Manufacturing Facilities

Ramset™

Established in Australia over fifty years ago, Ramset™ has built a strong and enviable reputation for developing, manufacturing and supplying the building and construction industry with leading edge drilling, anchoring and fixing products.

The Ramset™ Chemical Anchoring is one of the top leading brands in Southeast Asia due to its high quality, reliability and versatility for anchoring threaded stud, rebar and starter bar into solid and hollow substrates. Our Australia-made Epcon G5pro, has become the preferred choice of the contractors when it comes to jobsite productivity as it is the only fast cure epoxy adhesive available in the market.

Ramset™ Gas Fastening System employs the latest Spit's Pulsa technology to fasten to concrete, steel and other common building materials. This revolutionary Pulsa Technology, since its first introduction in Europe in 1992, has changed the way fastening works are done around the world.



ITW Construction Systems International
1 Ramset Drive
Chirnside Park,
Victoria 3116
Australia



ITW Red Head
2171 Executive Drive
Addison, IL 60101
USA

Spit

Spit is the proven expert in fixing and drilling. Founded in 1981 in southern France, Spit has developed a vast experience of European construction which has enabled it to develop a comprehensive range of anchors, resins, nailers and rotary hammer drills.

The R&D Team at Spit continually creates new innovations for the benefit of the construction industry, which reduce the overall environmental impact and improves health and safety whilst on site.

Unlike any direct competitor, Spit develops and manufactures a significant portion of its product range in Europe for both local and overseas markets. The professionals' selection of mechanical anchors have been extensively and rigorously tested to exceed the most demanding Eurocode's requirements.



Société Spit
(an ITW Construction Europe organization)
Route de Lyon
F-26501 BOURG-LES-VALENCE
France

Buildex®

Established in Australia in 1917, Buildex® is an industry pioneer with innovations such as Hi-Grip®, ShankGuard® and RoofZip®. Buildex® invented the Teks® self-drilling screws which revolutionized the roofing and cladding market and the rest is history.

All Buildex® fasteners are designed to do their particular job more efficiently and effectively than conventional fasteners. When you are using Buildex® Fasteners you are using the most modern fastener available.

The Buildex® manufacturing plant in Melbourne, Australia produces fasteners to exacting high standards of quality and are subjected to strict inspection and testing procedures.

While any direct competitor may meet minimum requirement of the traditional "accelerated" laboratory test, Buildex® exposes its fasteners to the combination of corrosive influences that exist in the "real world" including salt spray, humidity, uv light, acid rain and compatibility with roofing sheet.

Reid™

Reid™ has a history spanning almost 90 years as a supplier of solutions to the mining and construction industries in Australia. In the 21st century, Reid™ is at the forefront of concrete reinforcement, anchoring, fastening and fixing technologies, with the design of precast concrete and tilt-up concrete construction systems a particular specialty. Reid™ product design and development team possesses over 200 years of collective engineering experience.

Reid™ manufactures and supplies well-known brands such as SwiftLift™ Concrete Lifting Systems, Spartan™ Formwork System, Reid™ connection systems and the revolutionary architectural patterned concrete technologies such as Fitzgerald™ Formliners and Graphic Concrete™ range of products. Reid products help solve construction problems and enable better performing buildings to be constructed more quickly, more efficiently and at a lower overall cost.

METHOD STATEMENT FOR NON-DESTRUCTIVE TENSILE TEST ON RAMSET EPCON G5 PRO CHEMICAL WITH REBARS INSTALLED

1. Prior to carrying out the test, the test equipment (Hydraulic Jack System with calibration certification attached) must be setup in position according to BS5080 Part 1.
2. The loading frame is placed through the rebar and sits directly on the base concrete. The appropriate type of hydraulic jack is mounted on top of the loading frame and wedged in place with a corresponding wedge system to engage the rebar tightly at the end of the setup before applying the load.
3. A central load is applied gradually by means of the hydraulic jack system, via a hollow piston cylinder onto the wedges to create a reaction force equaling to a tensile pull-out effect, up to the required design test load.
4. The load achieved is indicated in the calibrated pressure gauge, usually expressed in KiloNewtons (kN) for ease of load determination. During or at the end of the loading, the achieved load and the mode of failure, if any, are recorded in the field test record form. The recorded field test record form shall be acknowledged by all parties present, namely the tester, the contractor and the consultant and shall form part of the final test report to be submitted to the contractor for filing purpose.

TEST SETUP (N.T.S.)

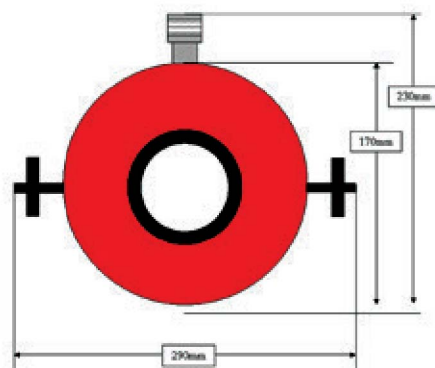
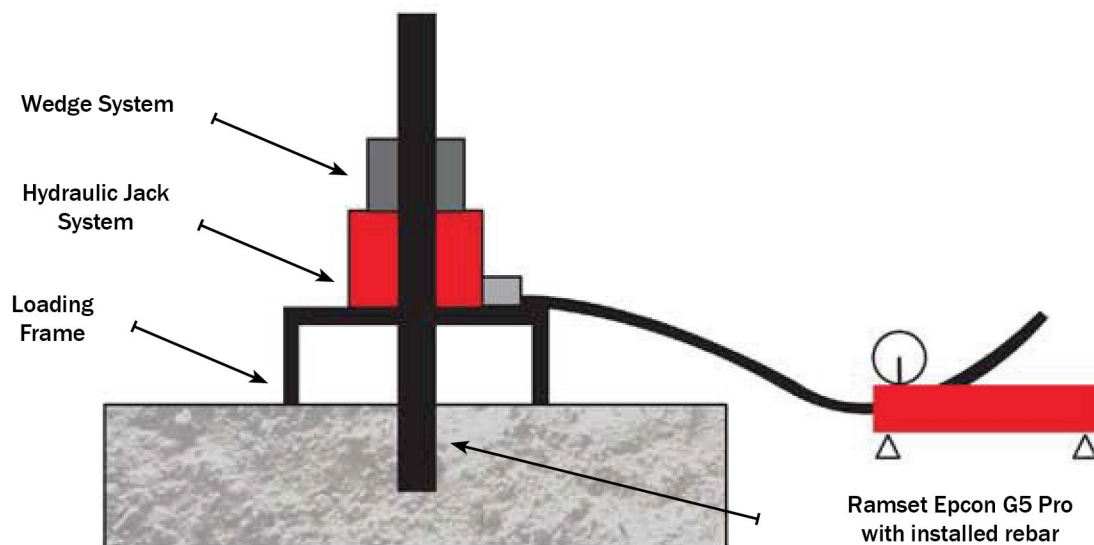

DIMENSION OF HOLLOW JACK

* For different diameters of anchors, the dimensions of the hollow jack may vary

EPCON™ G5 PRO

CHEMICAL INJECTION - NON-CRACKED & CRACKED CONCRETE

GENERAL INFORMATION

Performance Related	Material Specification	Installation Related

PRODUCT

EPCON™ G5 PRO is a heavy duty pure Epoxy for anchoring threaded studs and reinforcing bar into cracked and uncracked concrete.



COMPLIANCE

European Technical Assessment (option 1) - ETA-18/0675

Design according to:

- EN1992-4 (formerly ETAG001 Annex C, E & TR045)

BENEFITS, ADVANTAGES AND FEATURES

- 100 year working life

Greater productivity:

- Anchors in dry, damp, wet or flooded holes
- Easy dispensing even in cold weather

Greater security:

- Strong bond
- Rated for sustained loading

Versatile:

- Anchors in carbide drilled and diamond drilled holes*
- Cold and temperate climates

Greater safety:

- Low odour
- VOC Compliant



Principal Applications

- Threaded Studs
- Starter Bars
- Threaded Inserts
- Over-head installation
- Steel Columns
- Hand Rails
- Road Stitching

RECOMMENDED INSTALLATION TEMPERATURES

	Minimum	Maximum
Substrate	5°C	40°C
Adhesive	10°C	40°C

SERVICE TEMPERATURE LIMITS

-40°C to 70°C

SETTING TIMES

Base Material Temperature [°C]	Cartridge Temperature [°C]	T Work [mins]	T Load [hrs]
+5	Minimum +10	300	24
+5°C to +10		150	
+10°C to +15	+10°C to +15	40	18
+15°C to +20	+15°C to +20	25	12
+20°C to +25	+20°C to +25	18	8
+25°C to +30	+25°C to +30	12	6
+30°C to +35	+30°C to +35	8	4
+35°C to +40	+35°C to +40	6	2
Ensure cartridge is ≥ 10°C			

T Work is typical gel time at highest base material temperature in the range.
T Load is minimum set time required until load can be applied at the lowest temperature in the range.

INSTALLATION

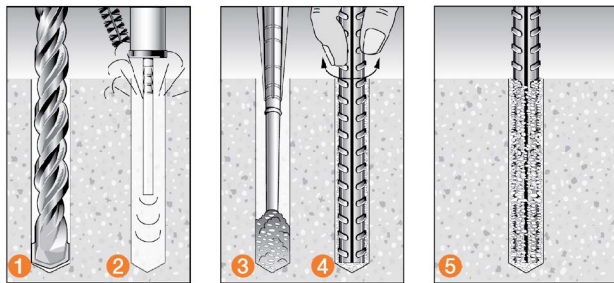

1. Drill recommended diameter and depth hole.
2. **Important:** Use Ramset™ Dustless Drilling System to ensure holes are clean. Alternatively, clean dust and debris from hole with stiff wire or nylon brush and blower in the following sequence: blow x 2, brush x 2, blow x 2, brush x 2, blow x 2.
3. Dispense adhesive to waste until colour is uniform light grey (2-3 trigger pulls). Insert mixing nozzle to bottom of hole. Fill hole to 3/4 the hole depth slowly, ensuring no air pockets form.
4. Insert Ramset™ ChemSet™ Anchor Stud/rebar to bottom of hole while turning.
5. Allow EPCON™ G5 PRO to cure as per setting times.

EPCON™ G5 PRO

REBAR APPLICATION

HIGH STRENGTH EPOXY

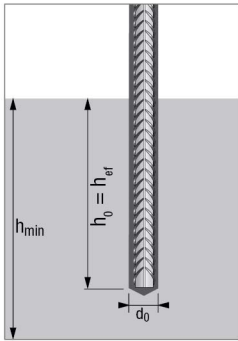

Technical data							
Rebar Diameter	Rebar depth	Minimum Thickness of Member	Standard Drill depth	Min Spacing	Min Edge distance	Drill hole diameter	Torque moment
(mm)	(mm)	(mm)	(mm)	(mm)	(mm)	(mm)	(Nm)
d	h _{ef}	h _{min}	h _o	S _{min}	C _{min}	d _o	T _{inst}
Ø8	80	115	80	40	40	12	10
Ø10	90	125	90	40	40	13	20
Ø12	110	145	110	40	40	15	40
Ø16	125	162	125	40	40	20	80
Ø20	170	215	170	50	50	25	120
Ø25	210	265	210	50	50	30	180
Ø32	280	349	280	70	70	40	200

Rebar Mechanical Properties								
Rebar Diameter		Ø8	Ø10	Ø12	Ø16	Ø20	Ø25	Ø32
Cross Section (mm ²)		50.3	78.5	113	201	314	491	804
CB 300-V	min yield strength f _{yk}	(N/mm ²)	300	300	300	300	300	300
	min tensile strength f _{uk}		450	450	450	450	450	450
CB 400-V	min yield strength f _{yk}	(N/mm ²)	400	400	400	400	400	400
	min tensile strength f _{uk}		570	570	570	570	570	570
CB 500-V	min yield strength f _{yk}	(N/mm ²)	500	500	500	500	500	500
	min tensile strength f _{uk}		650	650	650	650	650	650

EPCON™ G5 PRO

REBAR APPLICATION

Performance data from European Technical Assessment ETA-18/0675

HIGH STRENGTH EPOXY

The data given in the RAMSET CC Method have to be applied (refer to pages 4 to 5)

Rebar Diameter	8	10	12	16	20	25	32
Drilling ø (mm)	12	13	15	20	25	30	40
Drilling depth (mm)	80	90	110	125	170	210	280
Consumption per hole (ml)	5.0	6.6	10.7	21.6	45.9	81.6	193.4
EPCON G5 Pro (600ml)	120.6	91.4	56.1	27.8	13.1	7.4	3.1

CHARACTERISTIC LOADS (N_{Rk} , V_{Rk}) in kN

Characteristic loads are statistically determined from ETA-18/0675 & EN 1992-4 in admissible service conditions

.Tension resistance based on minimum of rebar tensile resistance, concrete cone resistance, combined pullout & concrete resistance

.Shear resistance based on minimum of rebar shear resistance, concrete pry-out resistance

- Input material : + Concrete grade : C20/25 (Uncracked concrete)
- + Rebar grade : CB 300-V
- + No edge distance

TENSILE							
Rebar Size	Ø8	Ø10	Ø12	Ø16	Ø20	Ø25	Ø32
h_{ef} (mm)	80	90	110	125	170	210	280
N_{Rk} (kN)	22.6	35.3	50.9	68.7	109.1	149.7	225.2

SHEAR							
Rebar Size	Ø8	Ø10	Ø12	Ø16	Ø20	Ø25	Ø32
V_{Rk} (kN)	13.6	21.2	30.5	54.3	84.8	132.5	217.1

DESIGN LOADS (N_{Rd} , V_{Rd}) FOR ONE ANCHOR WITHOUT EDGE OR SPACING INFLUENCE IN kN

$$N_{Rd} = \frac{N_{Rk}^*}{\gamma_M}$$

$$V_{Rd} = \frac{V_{Rk}^*}{\gamma_M}$$

TENSILE							
Rebar Size	Ø8	Ø10	Ø12	Ø16	Ø20	Ø25	Ø32
h_{ef} (mm)	80	90	110	125	170	210	280
N_{Rd} (kN)	12.6	19.6	28.3	45.8	72.7	99.8	150.1

SHEAR							
Rebar Size	Ø8	Ø10	Ø12	Ø16	Ø20	Ø25	Ø32
V_{Rd} (kN)	9.0	14.1	20.3	36.2	56.5	88.3	144.7

γ_M refer to tensile safety factor page 4

γ_M refer to safety factor for shear page 4

RECOMMENDED LOADS (N_{Rec} , V_{Rec}) FOR ONE ANCHOR WITHOUT EDGE OR SPACING INFLUENCE IN kN

$$N_{Rec} = \frac{N_{Rk}^*}{\gamma_M \times \gamma_F}$$

$$V_{Rec} = \frac{V_{Rk}^*}{\gamma_M \times \gamma_F}$$

TENSILE							
Rebar Size	Ø8	Ø10	Ø12	Ø16	Ø20	Ø25	Ø32
h_{ef} (mm)	80	90	110	125	170	210	280
N_{Rec} (kN)	9.0	14.0	20.2	32.7	51.9	71.2	107.2

SHEAR							
Rebar Size	Ø8	Ø10	Ø12	Ø16	Ø20	Ø25	Ø32
V_{Rec} (kN)	6.4	10.1	14.5	25.9	40.4	63.1	103.4
$\gamma_F = 1.4$							

$\gamma_F = 1.4$

EPCON™ G5 PRO

REBAR APPLICATION

Performance data from European Technical Assessment ETA-18/0675

RAMSET CC-METHOD

TENSILE in kN

Combined Pull-Out & Concrete Resistance
C20/25 - for dry and wet concrete [1]
 $N_{Rd,p} = N_{Rd,p}^0 \cdot f_T \cdot f_B$

$N_{Rd,p}^0$ Design combined pull-out & concrete resistance	Ø8	Ø10	Ø12	Ø16	Ø20	Ø25	Ø32
h_{ef} (mm)	80	90	110	125	170	210	280
Un-cracked concrete	17.4	24.5	35.9	50.3	85.5	131.9	150.1
Cracked concrete	10.7	20.7	27.6	41.9	71.2	93.5	122.0

$\gamma_{Mc} = 1.5$

Concrete Cone Resistance
C20/25 - for dry and wet concrete [1]
 $N_{Rd,c} = N_{Rd,c}^0 \cdot f_B \cdot f_T \cdot \Psi_s \cdot \Psi_{c,N}$

$N_{Rd,c}^0$ Design cone resistance	Ø8	Ø10	Ø12	Ø16	Ø20	Ø25	Ø32
h_{ef} (mm)	80	90	110	125	170	210	280
Un-cracked concrete	23.5	28.0	37.8	45.8	72.7	99.8	153.7
Cracked concrete	16.4	19.6	26.5	32.1	50.9	69.9	107.6

$\gamma_{Mc} = 1.5$

Steel tensile resistance

$N_{Rd,s}$ Steel design tensile resistance	Ø8	Ø10	Ø12	Ø16	Ø20	Ø25	Ø32
Rebar Size							
Rebar CB 300-V	12.6	19.6	28.3	50.2	78.5	122.7	201.0
Rebar CB 400-V	16.7	26.2	37.7	67.0	104.7	163.5	267.9
Rebar CB 500-V	20.9	32.7	47.1	83.7	130.8	204.4	334.9

$\gamma_{Ms}^{CB\ 300-V} = 1.5$ $\gamma_{Ms}^{CB\ 400-V} = 1.71$ $\gamma_{Ms}^{CB\ 500-V} = 1.56$

[1] The concrete in the area of the anchorage is water saturated. The anchor will be installed in flooded holes but figures above cannot be used, you must apply a further partial safety factor of $\gamma_{inst} = 1.2$ as stipulated in the ETA.

$$N_{Rd} = \min(N_{Rd,p}; N_{Rd,c}; N_{Rd,s})$$

$$\beta N = N_{Sd} / N_{Rd} \leq 1$$

$$V_{Rd} = \min(V_{Rd,c}; V_{Rd,s}; V_{Rd,cp})$$

$$\beta V = V_{Sd} / V_{Rd} \leq 1,$$

$$\beta N = \beta V \leq 1.2$$

f_T INFLUENCE OF EMBEDMENT DEPTH

$$f_T = \frac{h_{act}}{h_{ef}} \quad \text{where: } h_{act} \leq 2h_{ef}$$

f_B INFLUENCE OF CONCRETE

Concrete Class	f_B
C20/25	1.00
C25/30	1.02
C30/37	1.04
C35/45	1.06
C40/50	1.07
C45/55	1.08
C50/60	1.09

$f_{\beta,v}$ INFLUENCE OF SHEAR LOADING DIRECTION

Angle β [°]	$f_{\beta,v}$
0 ~ 50	1.0
60	1.1
70	1.2
80	1.5
90 ~ 180	2.0

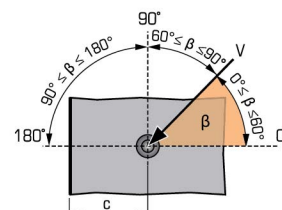

SHEAR in kN

Concrete Edge Resistance C20/25
 $V_{Rd,c} = V_{Rd,c}^0 \cdot f_B \cdot f_{\beta,v} \cdot \Psi_{s-c,V}$

$V_{Rd,c}^0$ Design concrete edge resistance at minimum edge distance (C_{min})	Ø8	Ø10	Ø12	Ø16	Ø20	Ø25	Ø32
h_{ef} (mm)	80	90	110	125	170	210	280
c_{min}	40	40	40	40	50	50	70
s_{min}	40	40	40	40	50	50	70
Un-cracked concrete	3.3	3.6	4.0	4.4	6.7	7.8	13.6
Cracked concrete	2.4	2.5	2.8	3.1	4.8	5.5	9.6

$\gamma_{Mc} = 1.5$

Concrete Pry-Out Failure C20/25
 $V_{Rd,cp} = V_{Rd,cp}^0 \cdot f_B \cdot \Psi_s \cdot \Psi_{c,N}$
where $V_{RK,cp} = K8 \cdot \min(N_{RK,c}^0; N_{RK,p}^0)$

$V_{Rd,cp}^0$ Design pryout resistance	Ø8	Ø10	Ø12	Ø16	Ø20	Ø25	Ø32
Rebar Size							
Un-cracked concrete	34.9	49.0	71.9	91.7	145.4	199.6	300.3
Cracked concrete	21.5	39.2	53.0	64.2	101.8	139.7	215.1

$\gamma_{Mc} = 1.5$

Steel shear resistance

$V_{Rd,s}$ Steel design shear resistance	Ø8	Ø10	Ø12	Ø16	Ø20	Ø25	Ø32
Rebar Size							
Rebar CB 300-V	9.0	14.1	20.3	36.2	56.5	88.3	144.7
Rebar CB 400-V	10.0	15.7	22.6	40.2	62.8	98.1	160.8
Rebar CB 500-V	12.6	19.6	28.3	50.2	78.5	122.7	201.0

$\gamma_{Ms}^{CB\ 300-V} = 1.5$ $\gamma_{Ms}^{CB\ 400-V} = 1.43$ $\gamma_{Ms}^{CB\ 500-V} = 1.30$

EPCON™ G5 PRO

PERFORMANCE DERIVED FROM ETA - REBAR

RAMSET CC-METHOD

Ψ_s INFLUENCE OF SPACING FOR CONCRETE CONE RESISTANCE IN TENSILE LOAD

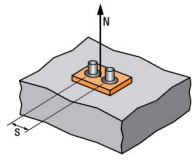

$$\Psi_s = 0.5 + \frac{s}{6 \cdot h_{ef}}$$

$s_{min} < s < s_{cr,N}$
 $s_{cr,N} = 3 \cdot h_{ef}$
 Ψ_s must be used for each spacing influenced the anchors group

SPACING s	Reduction factor Ψ_s Cracked & Non-cracked concrete			
	Anchor Size Ø8	Ø10	Ø12	Ø16
40	0.58	0.57	0.56	0.55
55	0.61	0.60	0.58	0.57
85	0.68	0.66	0.63	0.61
105	0.72	0.69	0.66	0.64
140	0.79	0.76	0.71	0.69
160	0.83	0.80	0.74	0.71
180	0.88	0.83	0.77	0.74
240	1.00	0.94	0.86	0.82
270		1.00	0.91	0.86
330			1.00	0.94
375				1.00

SPACING s	Reduction factor Ψ_s Cracked & Non-cracked concrete		
	Anchor Size Ø20	Ø25	Ø32
50	0.55	0.54	
70	0.57	0.56	0.54
85	0.58	0.57	0.55
105	0.60	0.58	0.56
210	0.71	0.67	0.63
250	0.75	0.70	0.65
350	0.84	0.78	0.71
420	0.91	0.83	0.75
510	1.00	0.90	0.80
630		1.00	0.88
840			1.00

$\Psi_{c,N}$ INFLUENCE OF EDGE FOR CONCRETE CONE RESISTANCE IN TENSILE LOAD

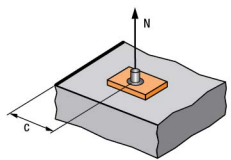

$$\Psi_{c,N} = 0.25 + 0.5 \cdot \frac{c}{h_{ef}}$$

$c_{min} < c < c_{cr,N}$
 $c_{cr,N} = 1.5 \cdot h_{ef}$
 $\Psi_{c,N}$ must be used for each spacing influenced the anchors group

EDGE c	Reduction factor $\Psi_{c,N}$ Cracked & Non-cracked concrete			
	Anchor Size Ø8	Ø10	Ø12	Ø16
40	0.50	0.47	0.43	0.41
55	0.59	0.56	0.50	0.47
85	0.78	0.72	0.64	0.59
90	0.81	0.75	0.66	0.61
100	0.88	0.81	0.70	0.65
110	0.94	0.86	0.75	0.69
120	1.00	0.92	0.80	0.73
135		1.00	0.86	0.79
165			1.00	0.91
187				1.00

EDGE c	Reduction factor $\Psi_{c,N}$ Cracked & Non-cracked concrete		
	Anchor Size Ø20	Ø25	Ø32
50	0.40	0.37	
70	0.46	0.42	0.38
85	0.50	0.45	0.40
105	0.56	0.50	0.44
135	0.65	0.57	0.49
150	0.69	0.61	0.52
170	0.75	0.65	0.55
255	1.00	0.86	0.71
315		1.00	0.81
420			1.00

$\Psi_{s-c,V}$ INFLUENCED OF SPACING AND EDGE DISTANCE FOR CONCRETE EDGE RESISTANCE IN SHEAR LOAD

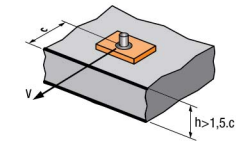

$$\Psi_{s-c,V} = \frac{c}{c_{min}} \cdot \sqrt{\frac{c}{c_{min}}}$$

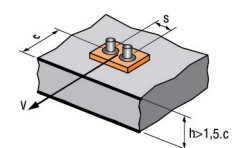

$$\Psi_{s-c,V} = \frac{3 \cdot c + s}{6 \cdot c_{min}} \cdot \sqrt{\frac{c}{c_{min}}}$$

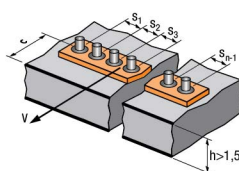

For single anchor fastening		Factor $\Psi_{s-c,V}$ Cracked & Non-cracked concrete											
$\frac{c}{c_{min}}$		1.0	1.2	1.4	1.6	1.8	2.0	2.2	2.4	2.6	2.8	3.0	3.2
$\Psi_{s-c,V}$		1.00	1.31	1.66	2.02	2.41	2.83	3.26	3.72	4.19	4.69	5.20	5.72

For 2 anchors fastening		Factor $\Psi_{s-c,V}$ Cracked & Non-cracked concrete												
$\frac{c}{c_{min}}$	$\frac{c}{c_{min}}$	1.0	1.2	1.4	1.6	1.8	2.0	2.2	2.4	2.6	2.8	3.0	3.2	
1.0		0.67	0.84	1.03	1.22	1.43	1.65	1.88	2.12	2.36	2.62	2.89	3.16	
1.5		0.75	0.93	1.12	1.33	1.54	1.77	2.00	2.25	2.50	2.76	3.03	3.31	
2.0		0.83	1.02	1.22	1.43	1.65	1.89	2.12	2.38	2.63	2.90	3.18	3.46	
2.5		0.92	1.11	1.32	1.54	1.77	2.00	2.25	2.50	2.77	3.04	3.32	3.61	
3.0		1.00	1.20	1.42	1.64	1.88	2.12	2.37	2.63	2.90	3.18	3.46	3.76	
3.5			1.30	1.52	1.75	1.99	2.24	2.50	2.76	3.04	3.32	3.61	3.91	
4.0				1.62	1.86	2.10	2.36	2.62	2.89	3.17	3.46	3.75	4.05	
4.5					1.96	2.21	2.47	2.74	3.02	3.31	3.60	3.90	4.20	
5.0						2.33	2.59	2.87	3.15	3.44	3.74	4.04	4.35	
5.5							2.71	2.99	3.28	3.57	3.88	4.19	4.50	
6.0								2.83	3.11	3.41	3.71	4.02	4.33	4.65

For other case of fastenings	
$\Psi_{s-c,V}$	$= \frac{3 \cdot c + s_1 + s_2 + s_3 + \dots + s_{n-1}}{3 \cdot n \cdot c_{min}} \cdot \sqrt{\frac{c}{c_{min}}}$

EPCON™ G5 PRO

INSTALLATION IN REINFORCED CONCRETE - REBAR

EXAMPLE:

The design action effect which causes tension in the starter bar is:

$$N = 650\text{kN/m run}$$

Strip footing details:

Concrete grade = 25N/mm²

Structure Thickness = 600mm

Concrete cover = 50mm

Load case induced in starter bar = 650kN/m run

Consider design of 460N/mm² grade reinforcement bar

To satisfy Strength Limit State Design Criteria,

$$N \leq A_s \times (f_{yk} \div \gamma_{ms})$$

Therefore $650,000(\text{N}) \leq A_s \times (460 \div 1.15)$

$$A_s \geq 1,624\text{mm}^2$$

Using 4T25 reinforcing bar @ 300mm c/c = 1,963.6mm² > 1,624mm²

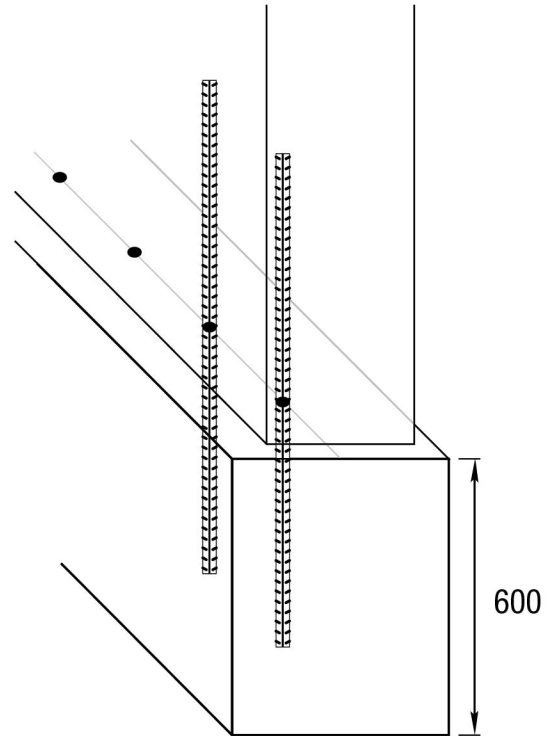

INSTALLING T25 WITH EPCON G5 PRO

$$L_b = \frac{L_{b,reqd}}{f_b} \cdot \frac{F_{Rd}}{N_{Rd,s}}$$

$$L_b = (340\text{mm} \div 0.90) \times (162.5\text{kN} \div 196.3\text{kN})$$

$$L_b = 312.7\text{mm} \dots \text{say } 315\text{mm}$$

EXAMPLE:

Where the existing structure is 350mm deep and concrete cover remains 50mm:

hole depth = 300mm

design tensile capacity for T25 @ 300mm embedment depth = 173.1kN x 0.9 = 155.7kN

650kN/m = n x 155.7kN

n = 650kN / 155.7kN = 4.17 » 5 (round to nearest whole number)

Use 5T25 reinforcing bar @ 225mm c/c = 2,454.5mm² > 1,624mm²

EPCON™ G5 PRO

PERFORMANCE DESIGN AS PER EN 1992-1-1 - REBAR

GENERAL POINTS

The design of rebar connections and determination of the internal section forces to be transferred in the construction joint shall be in keeping with the EN 1992-1-1.

Verification of immediate local force transfer to the concrete has been provided.

Verification of the transfer of the loads to the anchored to the building component must be provided.

CONNECTION JOINT

In case of a connection being made between new and existing concrete where the surface layer of the existing concrete is carbonated, the layer should be removed in the area of the new reinforcing bar (with a diameter $d_s + 60\text{mm}$) prior to the installation of the new bar. The forgoing may be neglected if building components are new and not carbonated.

To prevent damage of the concrete during drilling, the following requirements has to be met:

- Minimum concrete cover:
 $c_{\min} = 30 + 0.06l_v \geq 2d_s$ (mm) for hammer drilled holes
 where l_v = actual embedment depth
- Minimum distances between 2 rebars: $a = 40\text{mm} \geq 4d_s$
- Minimum embedment:
 $l_{b,\min} = 1.5 \times \text{Max}(0.3 \cdot L_{bd}; 10\emptyset; 100\text{mm})$

Furthermore, the minimum concrete cover according to EN 1992-1-1 SS 4.4.1.2 must be observed.

EPCON™ G5 PRO

PERFORMANCE DESIGN AS PER EN 1992-1-1 - REBAR

Applications when using performance data from European Technical Assessment ETA 20/0752

Overlap Joint

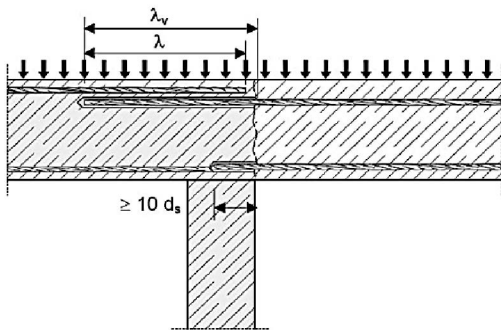

Figure A1: Overlap joint for rebar connections of slabs and beams.

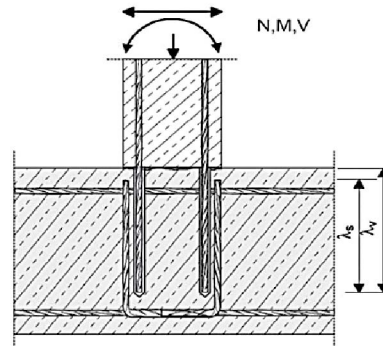

Figure A2: Overlap joint at a foundation of a column or wall where the rebars are stressed in tension.

Anchoring Bar

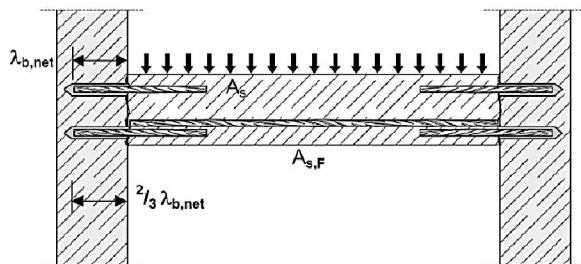

Figure A3: End anchoring of slabs or beams, designed as simply supported.

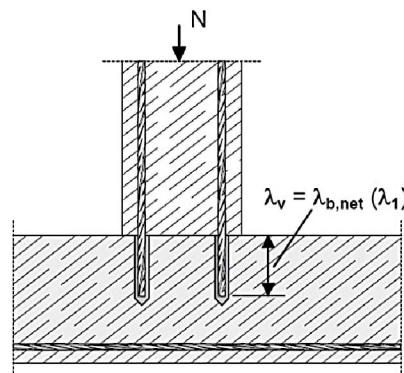

Figure A4: Rebar connection for components stressed primarily in compression. The rebars are stressed in compression.

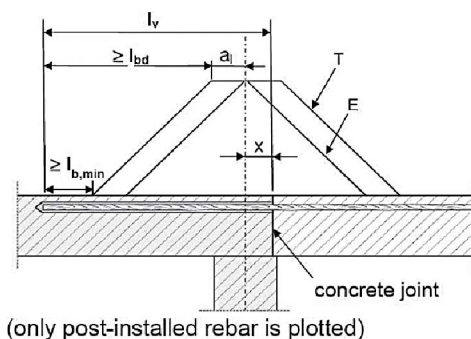

Figure A5: Anchoring of reinforcement to cover the line of acting tensile force.

EPCON™ G5 PRO

CHEMICAL INJECTION - NON-CRACKED & CRACKED CONCRETE

GENERAL INFORMATION

Performance Related	Material Specification	Installation Related
---------------------	------------------------	----------------------



PRODUCT

EPCON™ G5 PRO is a heavy duty pure Epoxy for anchoring threaded studs and reinforcing bar into cracked and uncracked concrete.

COMPLIANCE

European Technical Assessment (option 1) - ETA-18/0675

Design according to:

- EN1992-4 (formerly ETAG001 Annex C, E & TR045)

BENEFITS, ADVANTAGES AND FEATURES

- 100 year working life

Greater productivity:

- Anchors in dry, damp, wet or flooded holes
- Easy dispensing even in cold weather

Greater security:

- Strong bond
- Rated for sustained loading

Versatile:

- Anchors in carbide drilled and diamond drilled holes*
- Cold and temperate climates

Greater safety:

- Low odour
- VOC Compliant



Principal Applications

- Threaded Studs
- Starter Bars
- Threaded Inserts
- Over-head installation
- Steel Columns
- Hand Rails
- Road Stitching

RECOMMENDED INSTALLATION TEMPERATURES

	Minimum	Maximum
Substrate	5°C	40°C
Adhesive	10°C	40°C

SERVICE TEMPERATURE LIMITS

-40°C to 70°C

SETTING TIMES

Base Material Temperature [°C]	Cartridge Temperature [°C]	T Work [mins]	T Load [hrs]
+5	Minimum +10	300	24
+5°C to +10		150	
+10°C to +15	+10°C to +15	40	18
+15°C to +20	+15°C to +20	25	12
+20°C to +25	+20°C to +25	18	8
+25°C to +30	+25°C to +30	12	6
+30°C to +35	+30°C to +35	8	4
+35°C to +40	+35°C to +40	6	2

Ensure cartridge is ≥ 10°C

T Work is typical gel time at highest base material temperature in the range. T Load is minimum set time required until load can be applied at the lowest temperature in the range.

Installation

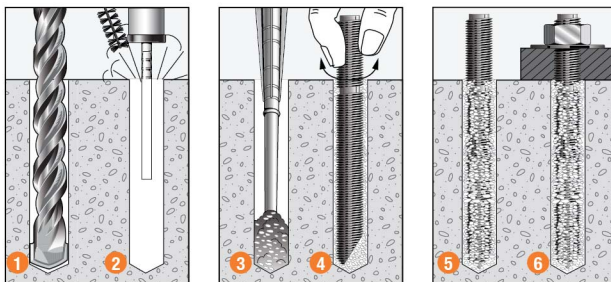

1. Drill recommended diameter and depth hole.
2. **Important:** Use Ramset™ Dustless Drilling System to ensure holes are clean. Alternatively clean dust and debris from hole with stiff wire or nylon brush and blower in the following sequence: blow x 2, brush x 2, blow x 2, brush x 2, blow x 2.
3. Dispense adhesive to waste until colour is uniform light grey (2-3 trigger pulls). Insert mixing nozzle to bottom of hole. Fill hole to 3/4 the hole depth slowly, ensuring no air pockets form.
4. Insert Ramset™ ChemSet™ Anchor Stud/rebar to bottom of hole while turning.
5. Allow EPCON™ G5 PRO to cure as per setting times.
6. Attach fixture.

EPCON™ G5 PRO

CHEMSET ANCHOR STUD APPLICATION

HIGH STRENGTH EPOXY

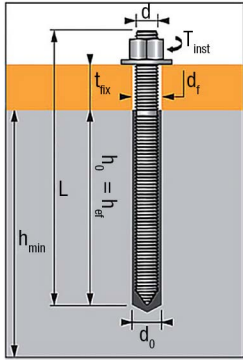

Technical data								
Anchor Stud Size (mm)	Anchor depth (mm)	Minimum Thickness of Member (mm)	Standard Drill depth (mm)	Min Spacing (mm)	Min Edge distance (mm)	Drill hole diameter (mm)	Clearance diameter (mm)	Torque moment (Nm)
d	h_{ef}	h_{min}	h₀	S_{min}	C_{ef}	∅d₀	d_r	T_{inst}
M8	80	115	80	40	40	10	9	10
M10	90	125	90	40	40	12	12	20
M12	110	145	110	40	40	14	14	40
M16	125	162	125	40	40	18	18	80
M20	170	215	170	50	50	25	22	120
M24	210	263	210	50	50	28	26	160
M30	280	345	280	60	60	35	33	200

* Values refer to ETA

Anchor Stud Mechanical Properties							
Chemset™ Anchor Studs Grade 5.8	M8	M10	M12	M16	M20	M24	M30
Min. Tensile Strength, f_{uk} (N/mm ² or MPa)	540	540	540	540	520	520	520
Yield Strength, f_{yk} (N/mm ² or MPa)	430	430	430	430	420	420	420
Nominal Stressed Area, $A_{s,nom}$ mm ²	36.6	58.0	84.3	157.0	245.0	353.0	561.0

Chemset™ Anchor Studs Stainless Steel A4	M8	M10	M12	M16	M20	M24	M30
Min. Tensile Strength, f_{uk} (N/mm ² or MPa)	700	700	700	700	700	700	-
Yield Strength, f_{yk} (N/mm ² or MPa)	350	350	350	350	350	350	-
Nominal Stressed Area, $A_{s,nom}$ (mm ²)	36.6	58.0	84.3	157.0	245.0	353.0	-

EPCON™ G5 PRO

CHEMSET ANCHOR STUD

HIGH STRENGTH EPOXY

The data given in the RAMSET CC Method have to be applied (refer to pages 4 to 5)

Stud diameter	8	10	12	16	20	24	30
Drilling ø (mm)	10	12	14	18	25	28	35
Drilling depth (mm)	80	90	110	125	170	210	280
Consumption per hole (ml)	3.5	5.6	9.3	17.5	45.9	71.1	148.1
EPCON G5 Pro (600ml)	173.7	107.2	64.5	34.3	13.1	8.4	4.1

CHARACTERISTIC LOADS (N_{Rk} , V_{Rk}) in kN

Characteristic loads are statistically determined from ETA-18/0675 & EN 1992-4 in admissible service conditions

.Tension resistance based on minimum of stud tensile resistance, concrete cone resistance, combined pullout & concrete resistance

.Shear resistance based on minimum of stud shear resistance, concrete pry-out resistance

Input material: + Chemset anchor stud 5.8
 + Concrete grade C20/25 (Uncracked concrete)
 + No edge distance

TENSILE							
Anchor size	M8	M10	M12	M16	M20	M24	M30
h_{ef} (mm)	80	90	110	125	170	210	280
N_{Rk} (kN)	18	29	42	68.7	109.1	149.7	230.6

SHEAR							
Anchor size	M8	M10	M12	M16	M20	M24	M30
V_{Rk} (kN)	9.0	15.0	21.0	39.0	61.0	88.0	140.0

DESIGN LOADS (N_{Rd} , V_{Rd}) FOR ONE ANCHOR WITHOUT EDGE OR SPACING INFLUENCE IN kN

$$N_{Rd} = \frac{N_{Rk}^*}{\gamma_{Mc}}$$

$$V_{Rd} = \frac{V_{Rk}^*}{\gamma_{Ms}}$$

TENSILE							
Anchor size	M8	M10	M12	M16	M20	M24	M30
h_{ef} (mm)	80	90	110	125	170	210	280
N_{Rd} (kN)	12.0	19.3	28.0	45.8	72.7	99.8	153.7

SHEAR							
Anchor size	M8	M10	M12	M16	M20	M24	M30
V_{Rd} (kN)	7.2	12.0	16.8	31.2	48.8	70.4	112.0

$\gamma_{Ms} = 1.25$

γ_{Mc} refer to tensile safety factor page 4

RECOMMENDED LOADS (N_{Rec} , V_{Rec}) FOR ONE ANCHOR WITHOUT EDGE OR SPACING INFLUENCE IN kN

$$N_{Rec} = \frac{N_{Rk}^*}{\gamma_{Mc} \times \gamma_F}$$

$$V_{Rec} = \frac{V_{Rk}^*}{\gamma_{Ms} \times \gamma_F}$$

TENSILE							
Anchor size	M8	M10	M12	M16	M20	M24	M30
h_{ef} (mm)	80	90	110	125	170	210	280
N_{Rec} (kN)	8.6	13.8	20.0	32.7	51.9	71.3	109.8

SHEAR							
Anchor size	M8	M10	M12	M16	M20	M24	M30
V_{Rec} (kN)	5.1	8.6	12.0	22.3	34.9	50.3	80.0

$\gamma_F = 1.4$

$\gamma_F = 1.4$

* Derived from test result assessed in ETA 18/0675

EPCON™ G5 PRO

CHEMSET ANCHOR STUD ZINC PLATED & STAINLESS STEEL STUDS

RAMSET CC-METHOD

TENSILE in kN

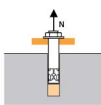

Pull-Out & Concrete Resistance
C20/25 - for dry, wet concrete and flooded hole

$$N_{Rd,p} = N_{Rd,p}^0 \cdot f_B$$

$N_{Rd,p}^0$ Design pull-out & concrete resistance							
Anchor size	M8	M10	M12	M16	M20	M24	M30
h_{ef} (mm)	80	90	110	125	170	210	280
Un-cracked concrete	22.8	28.3	41.5	50.3	85.5	126.7	167.1
Cracked concrete	13.4	18.8	27.6	39.8	64.1	95.0	105.6

$$\gamma_{Mc} = 1.5$$

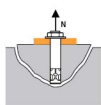

Concrete Cone Resistance
C20/25 - for dry, wet concrete and flooded hole

$$N_{Rd,c} = N_{Rd,c}^0 \cdot f_B \cdot \Psi_{s,c,N}$$

$N_{Rd,c}^0$ Design cone resistance							
Anchor size	M8	M10	M12	M16	M20	M24	M30
h_{ef} (mm)	80	90	110	125	170	210	280
Un-cracked concrete	23.5	28.0	37.8	45.8	72.7	99.8	153.7
Cracked concrete	16.4	19.6	26.5	32.1	50.9	69.9	107.6

$$\gamma_{Mc} = 1.5$$

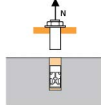

Steel tensile resistance

$N_{Rd,s}$ Steel design tensile resistance							
Anchor size	M8	M10	M12	M16	M20	M24	M30
ChemSet - A4 (SS)	13.9	21.9	31.6	58.8	92.0	132.1	-
Stud grade 5.8	12.0	19.3	28.0	52.7	82.0	118.0	187.3
Stud grade 8.8	19.3	30.7	44.7	84.0	130.7	188.0	299.3
Stud grade 10.9	27.8	43.6	63.2	118.0	184.2	265.4	421.8

Chemset A4: $\gamma_{Ms} = 1.87$

Stud grade 5.8 & 8.8: $\gamma_{Ms} = 1.50$

Stud grade 10.9: $\gamma_{Ms} = 1.33$

*Special grade available on request.

SHEAR in kN

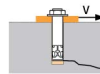

Concrete Edge Resistance C20/25

$$V_{Rd,c} = V_{Rd,c}^0 \cdot f_B \cdot \beta_V \cdot \Psi_{s-c,V}$$

$V_{Rd,c}^0$ Design concrete edge resistance at minimum edge distance (Cmin)							
Anchor size	M8	M10	M12	M16	M20	M24	M30
h_{ef} (mm)	80	90	110	125	170	210	280
c_{min}	40	40	40	40	50	50	60
s_{min}	40	40	40	40	50	50	60
Un-cracked concrete	3.3	3.6	4.0	4.4	6.7	7.7	11.3
Cracked concrete	2.4	2.5	2.8	3.1	4.8	5.5	8.0

$$\gamma_{Mc} = 1.5$$

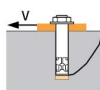

Concrete Pry-Out Failure C20/25

$$V_{Rd,cp} = V_{Rd,cp}^0 \cdot f_B \cdot \Psi_{s,c,N}$$

where $V_{RK,cp} = K8 \cdot \text{Min}(N_{RK,c}^0; N_{RK,p}^0)$

$V_{Rd,cp}^0$ Design pryout resistance							
Anchor size	M8	M10	M12	M16	M20	M24	M30
Un-cracked concrete	45.6	56.0	75.7	91.7	145.4	199.6	307.3
Cracked concrete	26.8	37.7	53.0	64.2	101.8	139.7	211.1

$$\gamma_{Mc} = 1.5$$

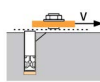

Steel shear resistance

$V_{Rd,s}$ Steel design shear resistance							
Anchor size	M8	M10	M12	M16	M20	M24	M30
ChemSet - A4 (SS)	8.3	12.8	19.2	35.3	55.1	79.5	-
Stud grade 5.8	7.2	12.0	16.8	31.2	48.8	70.4	112.0
Stud grade 8.8	12.0	18.4	27.2	50.4	78.4	112.8	179.2
Stud grade 10.9	12.0	19.3	28.0	52.7	82.0	118.0	187.3

Chemset A4: $\gamma_{Ms} = 1.56$

Stud grade 5.8 & 8.8: $\gamma_{Ms} = 1.25$

Stud grade 10.9: $\gamma_{Ms} = 1.50$

*Special grade available on request.

$$N_{Rd} = \min(N_{Rd,p}; N_{Rd,c}; N_{Rd,s})$$

$$\beta N = N_{Sd} / N_{Rd} \leq 1$$

$$V_{Rd} = \min(V_{Rd,c}; V_{Rd,s}; V_{Rd,cp})$$

$$\beta V = V_{Sd} / V_{Rd} \leq 1,$$

$$\beta N = \beta V \leq 1.2$$

f_B INFLUENCE OF CONCRETE

Concrete Class	f_B
C20/25	1.00
C25/30	1.02
C30/37	1.04
C35/45	1.06
C40/50	1.07
C45/55	1.08
C50/60	1.09

$f_{\beta,V}$ INFLUENCE OF SHEAR LOADING DIRECTION

Angle β [°]	$f_{\beta,V}$
0 ~ 50	1.0
60	1.1
70	1.2
80	1.5
90 ~ 180	2.0

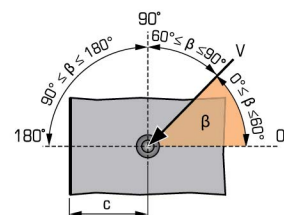

EPCON™ G5 PRO

CHEMSET ANCHOR STUD ZINC PLATED & STAINLESS STEEL STUDS

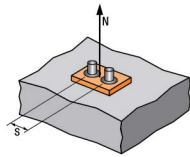

$$\Psi_s = 0.5 + \frac{s}{6 \cdot h_{ef}}$$

$s_{min} < s < s_{cr,N}$
 $s_{cr,N} = 3 \cdot h_{ef}$
 Ψ_s must be used for each spacing influenced the anchors group

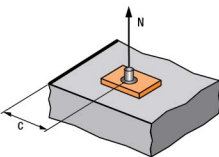

$$\Psi_{c,N} = 0.25 + 0.5 \cdot \frac{c}{h_{ef}}$$

$c_{min} < c < c_{cr,N}$
 $c_{min} = 1.5 \cdot h_{ef}$
 $\Psi_{c,N}$ must be used for each spacing influenced the anchors group

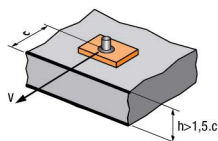

$$\Psi_{s-c,V} = \frac{c}{c_{min}} \cdot \sqrt{\frac{c}{c_{min}}}$$

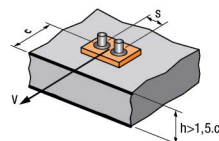

$$\Psi_{s-c,V} = \frac{3 \cdot c + s}{6 \cdot c_{min}} \cdot \sqrt{\frac{c}{c_{min}}}$$

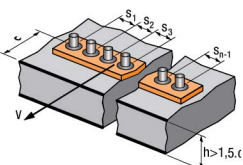

RAMSET CC-METHOD - STANDARD EMBEDMENT

Ψ_s INFLUENCE OF SPACING FOR CONCRETE CONE RESISTANCE IN TENSILE LOAD

SPACING s	Reduction factor Ψ_s Cracked & Non-cracked concrete			
	Anchor Size M8	M10	M12	M16
40	0.58	0.57	0.56	0.55
50	0.60	0.59	0.58	0.57
60	0.63	0.61	0.59	0.58
80	0.67	0.65	0.62	0.61
100	0.71	0.69	0.65	0.63
150	0.81	0.78	0.73	0.70
200	0.92	0.87	0.80	0.77
250	1.00	0.96	0.88	0.83
300		1.00	0.95	0.90
330			1.00	0.94
375				1.00

SPACING s	Reduction factor Ψ_s Cracked & Non-cracked concrete		
	Anchor Size M20	M24	M30
50	0.55	0.54	
60	0.56	0.55	0.54
100	0.60	0.58	0.56
180	0.68	0.64	0.61
200	0.70	0.66	0.62
250	0.75	0.70	0.65
350	0.84	0.78	0.71
450	0.94	0.86	0.77
510	1.00	0.90	0.80
630		1.00	0.88
750			0.95
840			1.00

$\Psi_{c,N}$ INFLUENCE OF EDGE FOR CONCRETE CONE RESISTANCE IN TENSILE LOAD

EDGE c	Reduction factor $\Psi_{c,N}$ Cracked & Non-cracked concrete			
	Anchor Size M8	M10	M12	M16
40	0.50	0.47	0.43	0.41
50	0.56	0.53	0.48	0.45
60	0.63	0.58	0.52	0.49
80	0.75	0.69	0.61	0.57
120	1.00	0.92	0.80	0.73
135		1.00	0.86	0.79
165			1.00	0.91
190				1.00

EDGE c	Reduction factor $\Psi_{c,N}$ Cracked & Non-cracked concrete		
	Anchor Size M20	M24	M30
50	0.40	0.37	
60	0.43	0.39	0.36
100	0.54	0.49	0.43
180	0.78	0.68	0.57
200	0.84	0.73	0.61
255	1.00	0.86	0.71
315		1.00	0.81
420			1.00

$\Psi_{s-c,V}$ INFLUENCED OF SPACING AND EDGE DISTANCE FOR CONCRETE EDGE RESISTANCE IN SHEAR LOAD

For single anchor fastening							Factor $\Psi_{s-c,V}$ Cracked & Non-cracked concrete					
C	1.0	1.2	1.4	1.6	1.8	2.0	2.2	2.4	2.6	2.8	3.0	3.2
$\frac{C}{c_{min}}$	1.00	1.31	1.66	2.02	2.41	2.83	3.26	3.72	4.19	4.69	5.20	5.72

For 2 anchors fastening							Factor $\Psi_{s-c,V}$ Cracked & Non-cracked concrete							
S	C	1.0	1.2	1.4	1.6	1.8	2.0	2.2	2.4	2.6	2.8	3.0	3.2	
$\frac{S}{c_{min}}$	$\frac{C}{c_{min}}$													
1.0	1.0	0.67	0.84	1.03	1.22	1.43	1.65	1.88	2.12	2.36	2.62	2.89	3.16	
1.5	1.0	0.75	0.93	1.12	1.33	1.54	1.77	2.00	2.25	2.50	2.76	3.03	3.31	
2.0	1.0	0.83	1.02	1.22	1.43	1.65	1.89	2.12	2.38	2.63	2.90	3.18	3.46	
2.5	1.0	0.92	1.11	1.32	1.54	1.77	2.00	2.25	2.50	2.77	3.04	3.32	3.61	
3.0	1.0	1.00	1.20	1.42	1.64	1.88	2.12	2.37	2.63	2.90	3.18	3.46	3.76	
3.5	1.0		1.30	1.52	1.75	1.99	2.24	2.50	2.76	3.04	3.32	3.61	3.91	
4.0	1.0			1.62	1.86	2.10	2.36	2.62	2.89	3.17	3.46	3.75	4.05	
4.5	1.0				1.96	2.21	2.47	2.74	3.02	3.31	3.60	3.90	4.20	
5.0	1.0					2.33	2.59	2.87	3.15	3.44	3.74	4.04	4.35	
5.5	1.0						2.71	2.99	3.28	3.57	3.88	4.19	4.50	
6.0	1.0							2.83	3.11	3.41	3.71	4.02	4.33	4.65

For other case of fastenings

$$\Psi_{s-c,V} = \frac{3 \cdot c + s_1 + s_2 + s_3 + \dots + s_{n-1}}{3 \cdot n \cdot c_{min}} \cdot \sqrt{\frac{c}{c_{min}}}$$

EPCON™ G5™ PRO - Physical Properties

Date: October 2021

Physical Properties of Ramset™ Epcon™ G5™ PRO (EG5P600) have been tested with the following results:

Physical Properties

Property		Value	Unit	Test Standard
Density		1,5	g/cm ³	ASTM D 1875 @ +20°C
Compressive Strength	24 hrs	90	N/mm ²	ASTM D 695 @ +20°C
	7 days	100		
Tensile Strength	24 hrs	25	N/mm ²	ASTM D 638 @ +20°C
	7 days	27		
Elongation at Break	24 hrs	6,6	%	ASTM D 638 @ +20°C
	7 days	5,7		
Tensile Modulus	24 hrs	6.7	GN/m ²	ASTM D 638 @ +20°C
	7 days	8.0		
Flexural Strength	24 hrs	45	N/mm ²	ASTM D 790 @ +20°C
HDT	7 days	49	°C	ASTM D 648 @ +20°C
VOC		0	g/l	ASTM D 2369

Sincerely,

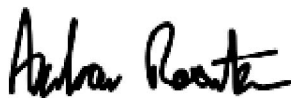

Andrew Rossiter
Ramset Product Manager



FINAL REPORT

Report ID : 320541

Report Information

Submitting Organisation : 00109275 : RamsetReid
Account : 130255 : RamsetReid
AWQC Reference : 130255-2021-CSR-1 : Prod Test:
Project Reference : PT-4685
Product Designation : Epcon™ G5 PRO
Composition of Product : Two Component Epoxy based adhesive. (2 Parts Resin to 1 Part Hardener).
Product Manufacturer : RAMSETREID (A DIVISION OF ITW AUSTRALIA PTY LTD), Ramset Drv, Chimside Pk, VIC, AUS
Use of Product : In-Line/Bonded Injection Type Anchor.
Sample Selection: As provided by the submitting organisation.
Testing Requested : **AS/NZS 4020 TESTING OF PRODUCTS FOR USE IN CONTACT WITH DRINKING WATER**
Product Type : Composite
Samples : Samples were prepared and controlled as described in Appendix A of AS/NZS 4020:2018
Extracts : Extracts were prepared as described in Appendix/Clause C, D, E, F, H, 6.8.
Project Completion Date : 23-Sep-2021
Project Comment : Sample received on the 15-Jul-2021, testing commenced on the 20-Jul-2021.

PLEASE NOTE THAT THIS REPORT SHALL NOT BE REPRODUCED EXCEPT IN FULL

THE RESULTS STATED IN THIS REPORT RELATE TO THE SAMPLE OF THE PRODUCT SUBMITTED FOR TESTING. ANY CHANGES IN THE MATERIAL FORMULATION, PROCESS OF MANUFACTURE, THE METHOD OF APPLICATION, OR THE SURFACE AREA-TO-VOLUME RATIO IN THE END USE, COULD AFFECT THE SUITABILITY OF THE PRODUCT FOR USE IN CONTACT WITH DRINKING WATER

Michael Glasson
APPROVED SIGNATORY



Corporate Accreditation No.1115
Chemical and Biological Testing
Accredited for compliance with ISO/IEC 17025





**Technical and Test Institute
for Construction Prague**
Prosecká 811/76a
190 00 Prague
Czech Republic
eota @tzus.cz



Member of



www.eota.eu

European Technical Assessment

**ETA 18/0675
of 06/06/2021**

Technical Assessment Body issuing the ETA:
for Construction Prague

Technical and Test Institute

Trade name of the construction product

Chemset TM Reo502 TM EF Plus
Epcon TM C6 EF Plus
Epcon TM G5 PRO

**Product family to which the construction
product belongs**

Product area code: 33
Bonded injection type anchor for use in
cracked and uncracked concrete

Manufacturer

Ramsetreid
A Division of ITW Australia Pty Ltd
1 Ramset Drive, Chirnside Park. Vic 3116
Australia

Manufacturing plant

Ramsetreid Plant

**This European Technical Assessment
contains**

19 pages including 16 Annexes which form
an integral part of this assessment.

**This European Technical Assessment is
issued in accordance with regulation
(EU) No 305/2011, on the basis of**

EAD 330499-01-0601
Bonded fasteners for use in concrete

This version replaces

ETA 18/0675 issued on 16/01/2020

Translations of this European Technical Assessment in other languages shall fully correspond to the original issued document and should be identified as such.

Communication of this European Technical Assessment, including transmission by electronic means, shall be in full (excepted the confidential Annex(es) referred to above). However, partial reproduction may be made, with the written consent of the issuing Technical Assessment Body - Technical and Test Institute for Construction Prague. Any partial reproduction has to be identified as such.



**Technical and Test Institute
for Construction Prague**
Prosecká 811/76a
190 00 Prague
Czech Republic
eota@tzus.cz



European Technical Assessment **ETA 20/0752**
of dd/mm/2021

Technical Assessment Body issuing the ETA:	Technical and Test Institute for Construction Prague
Trade name of the construction product	ChemSet™ Reo502™ EF Plus Epcon™ C6 EF Plus Epcon™ G5 PRO
Product family to which the construction product belongs	Product area code: 33 Post installed rebar connections with ChemSet™ Reo502™ EF Plus, Epcon™ C6 EF Plus, Epcon™ G5 PRO injection mortar
Manufacturer	Ramsetreid A Division of ITW Australia Pty Ltd 1 Ramset Drive, Chirnside Park. Vic 3116 Australia
Manufacturing plant	Ramsetreid Plant 3
This European Technical Assessment contains	16 pages including 13 Annexes which form an integral part of this assessment.
This European Technical Assessment is issued in accordance with regulation (EU) No 305/2011, on the basis of	EAD 330087-01-0601 Systems for post-installed rebar connections with mortar
This version replaces	ETA 20/0752 issued on 11/10/2020

Translations of this European Technical Assessment in other languages shall fully correspond to the original issued document and should be identified as such.

Communication of this European Technical Assessment, including transmission by electronic means, shall be in full (excepted the confidential Annex(es) referred to above). However, partial reproduction may be made, with the written consent of the issuing Technical Assessment Body - Technical and Test Institute for Construction Prague. Any partial reproduction has to be identified as such.

Job title: **Ramsetreid PIR ChemSet Reo502 EF Plus, Epcon C6 EF Plus, Epcon G5 PRO
Fire Analysis**

Report code: **259 - 2021- R01**

Report title: **Fire Evaluation of Post-installed rebar connections with Ramsetreid ChemSet
Reo502 EF Plus, Epcon C6 EF Plus, Epcon G5 PRO injection systems**

Draft by: **Doruk Gürkut, M.Sc.**

Reviewed by: **Leonardo Marconi, M.Sc.**

Endorsed by: **Dott.Ing. Giuseppe Muciaccia, M.Sc.**

Date: **November 4th, 2021**

Reviews

Rev.n.	Subject	Date	Pages	Approved by
01	Amendment of Tables: Table 7.3, Table 7.4, Table 7.5, Table 7.6, Table 7.7, Table 7.8, Table 7.9, Table 7.10, Table 8.1, Table 8.2 Figures: Figure 8.6, Figure 8.7	15/12/2021	21-52, 57,58	Leonardo Marconi, M.Sc.
02	Addition of concrete covers 100, 120, 140 and 160mm. Addition of Table 7.11, Table 7.12, Table 7.13, Table 7.14	03/01/2022	16, 53-69	Leonardo Marconi, M.Sc.
03	Figure 6.2 amended	11/01/2022	13	Leonardo Marconi, M.Sc.

SIGGMA SRL

VIA SETTALA 6 - 20124 MILANO - ITALY

TEL. +39.02.29531232 FAX. +39.02.29519616

